

LEFT HAND

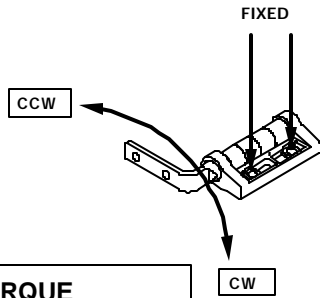

RIGHT HAND

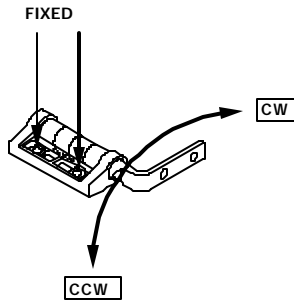

ROTATION
AS SHOWN FOR
CALLOUT OF
TORQUE

TORQUE

GEOMETRY	CW TORQUE	CCW TORQUE	HAND
ZE-375-CB-101	20	20	L
ZE-375-CB-101	20	20	R
ZE-375-CB-101	30	30	L
ZE-375-CB-101	30	30	R
ZE-375-CB-101	X	40	L
ZE-375-CB-101	40	X	R
ZE-375-CB-101	40	X	L
ZE-375-CB-101	X	40	R

CUSTOM TORQUE
CONFIGURATIONS AVAILABLE.
FOR QUOTE:
www.torqmaster.com
1-888-41-HINGE

REVISION RECORD

SYM	DESCRIPTION	BY	DATE	APPD
C	REDRAWN ON NEW FORMAT, NO CHANGES.	RMF	8/30/00	DJC

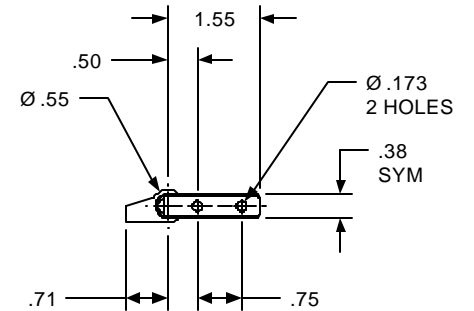
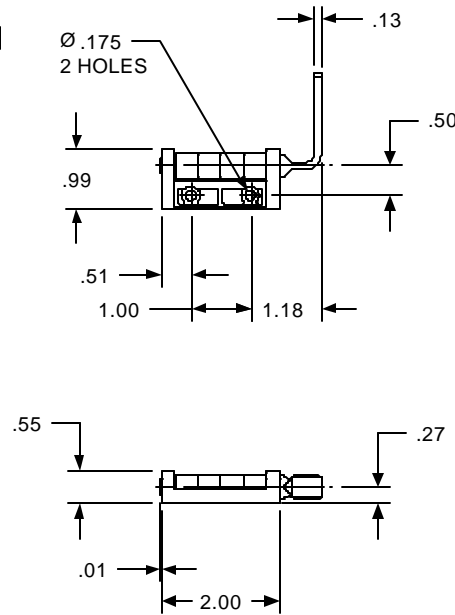

USED ON	SOLID	REV	TOLERANCES	DRAWN BY	DATE	ENGLISH		Torg Master, Inc. Stamford, CT USA	
STANDARD	101	0.0	ENGLISH	RA	5/9/97	MATERIAL		N/A	
NEXT ASSY	NONE		.XX ±.015 in .XXX ±.005 in .XXX ±.0002 in	CHECKED BY	DATE	TITLE			
QUANTITY				DJC	5/9/97	HINGE INTERFACE			
PER ASSY, pcs	-			SIZE					
TOTAL, pcs	-			B					
THIS INFORMATION IS PROPRIETARY TO TORQMASTER, INC. THE POSSESSOR AGREES TO MAINTAIN IT IN CONFIDENCE. NOT REPRODUCING OR REVEALING IT IN WHOLE OR IN PART.				SCALE					
				1:2		SHEET		1 OF 1	
						REV		C	
						ZE 375 CB 101			